



US Department of Transportation  
Federal Aviation Administration

## MAJOR REPAIR AND ALTERATION (Airframe, Powerplant, Propeller, or Appliance)

Form Approved  
OMB No. 2120-0020

**For FAA Use Only**

Office Identification

INSTRUCTIONS: Print or type all entries. See FAR 43.9, FAR 43 Appendix B, and AC 43.9-1 (or subsequent revision thereof) for instructions and disposition of this form. This report is required by law (49 U.S.C. 1421). Failure to report can result in a civil penalty not to exceed \$1,000 for each such violation (Section 901 Federal Aviation Act of 1958).

<b>1. Aircraft</b>	Make <b>TAYLORCRAFT</b>	Model <b>1946 BC12D</b>
	Serial No. <b>9857</b>	Nationality and Registration Mark <b>US. N44057</b>
<b>2. Owner</b>	Name (As shown on registration certificate) <b>JAMES A. SLOMER.</b>	Address (As shown on registration certificate) <b>114 DEBORAH LYNN COURT CHESWICK, PA 15024</b>

**3. For FAA Use Only**

4. Unit Identification				5. Type	
Unit	Make	Model	Serial No.	Repair	Alteration
AIRFRAME	~~~~~ (As described in Item 1 above) ~~~~~				✓
POWERPLANT					
PROPELLER					
APPLIANCE	Type				
	Manufacturer				

**6. Conformity Statement**

<b>A. Agency's Name and Address</b>	<b>B. Kind of Agency</b>	<b>C. Certificate No.</b>
	<input type="checkbox"/> U.S. Certificated Mechanic <input type="checkbox"/> Foreign Certificated Mechanic <input type="checkbox"/> Certificated Repair Station <input type="checkbox"/> Manufacturer	

D. I certify that the repair and/or alteration made to the unit(s) identified in item 4 above and described on the reverse or attachments hereto have been made in accordance with the requirements of Part 43 of the U.S. Federal Aviation Regulations and that the information furnished herein is true and correct to the best of my knowledge.

Date	Signature of Authorized Individual
------	------------------------------------

**7. Approval for Return To Service**

Pursuant to the authority given persons specified below, the unit identified in item 4 was inspected in the manner prescribed by the Administrator of the Federal Aviation Administration and is  APPROVED  REJECTED

<b>BY</b>	FAA Flt. Standards Inspector	Manufacturer	Inspection Authorization	Other (Specify)
	FAA Designee	Repair Station	Person Approved by Transport Canada Airworthiness Group	
Date of Approval or Rejection		Certificate or Designation No.	Signature of Authorized Individual	

### NOTICE

Weight and balance or operating limitation changes shall be entered in the appropriate aircraft record. An alteration must be compatible with all previous alterations to assure continued conformity with the applicable airworthiness requirements.

#### 8. Description of Work Accomplished

(If more space is required, attach additional sheets. Identify with aircraft nationality and registration mark and date work completed.)

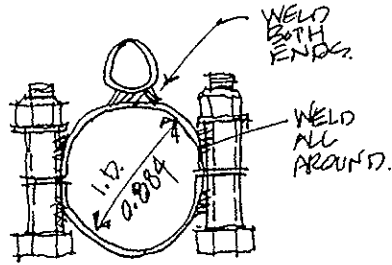
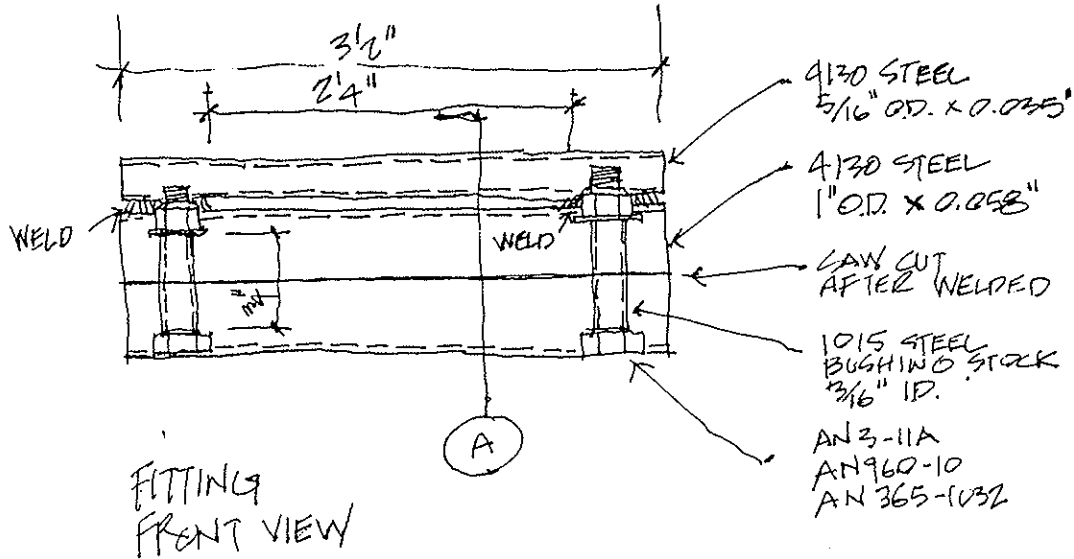

FITTING SIDE VIEW

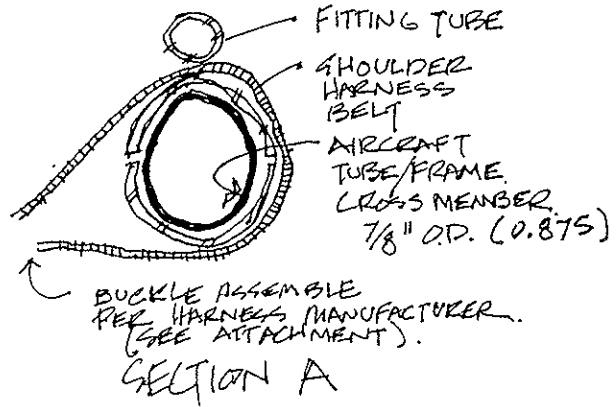

SECTION A

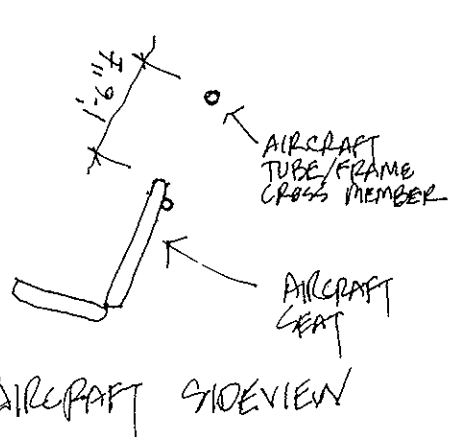

AIRCRAFT SIDEVIEW

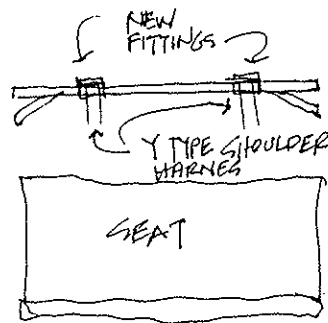

AIRCRAFT FRONTVIEW

(4)

Additional Sheets Are Attached